

MADAULA S.A.

www.madaula.com



ANGLE HEADS
TÊTES À RENVOIR D'ANGLE
WINKELKÖPFE
CABEZALES ANGULARES



001



More than 50 years increasing productivity
Plus de 50 ans au service de la productivité
Über 50 Jahre zum Dienst der Produktivität
Más de 50 años incrementando la productividad



A very performant team at your service
Une équipe très compétente à votre service
Ein sehr Kompetentes Team zu Ihrer Verfügung
Un equipo altamente competente a su servicio



MADAULA S.A.
www.madaula.com®





▷ SERIE CA	90° Angle heads Têtes à renvoi à 90° Winkelköpfe 90° Cabezales angulares a 90°	4
▷ SERIE CAR	Adjustable angle heads 0°-90° Têtes à renvoi réglables 0°-90° Vertellbare Winkelköpfe 0°-90° Cabezales angulares regulables 0°-90°	5
▷ SERIE CART	Adjustable angle heads 0°-90° (titanium) Têtes à renvoi réglables 0°-90° (titanium) Verstellbare Winkelköpfe 0°-90° (titan) Cabezales angulares regulables 0°-90° (titanio)	6
▷ SERIE CAR X	Adjustable angle heads with increasing ratio Têtes à renvoi réglables avec rapport multiplicateur Verstellbare Winkelköpfe mit Übersetzungsverhältnis Cabezales angulares regulables con relación multiplicadora	6
▷ SERIE CAF	Fixed angle heads Têtes à renvoi-angle fixe Feste Winkelköpfe Cabeles angulares a ángulo fijo	7
▷ SERIE CAP	Angle heads for inside-holes working Têtes à renvoi pour intérieurs d'alésages Winkelköpfe mit schmales Bauform Cabezales angulares para trabajos en espacios reducidos	8
▷ SERIE CAD	Double output angle heads Têtes à renvoi à double sortie Winkelköpfe mit Doppelausgang Cabezales angulares doble salida	9
▷ SPECIALS	Customized solutions Fabrications suivant plan Sonderfertigung Fabricaciones especiales	10
▷ INFO	Information Information Information Información	11

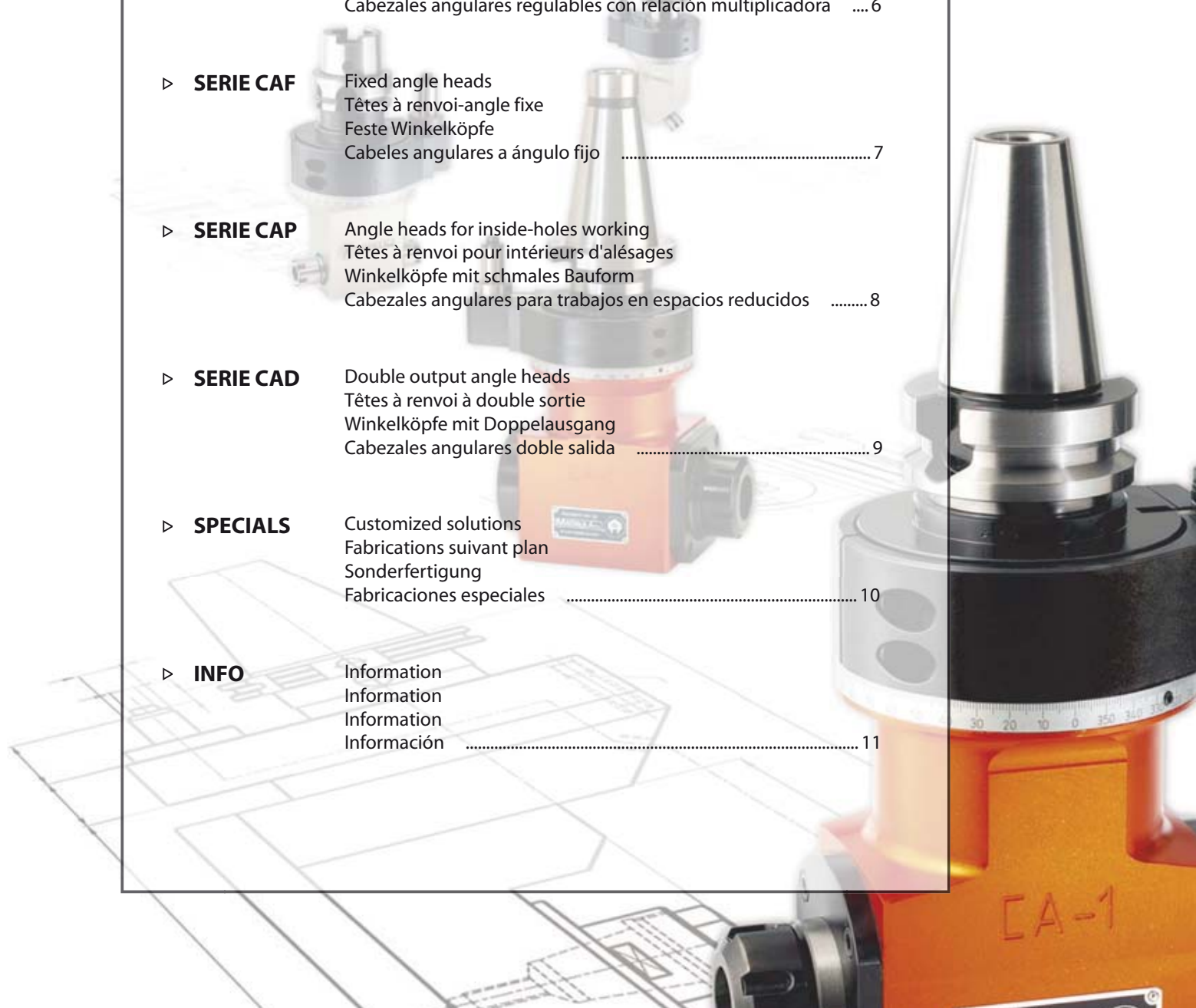



- ▶ Hermetically sealed spindle
- ▶ Parfaite étanchéité de la broche
- ▶ Hermetische Abdichtung des Spindels
- ▶ Husillo perfectamente hermético

- ▶ Precise and rigid compact manufacture
- ▶ Fabrication de précision, solide et très rigide
- ▶ Präzise und solide, starre Bauart
- ▶ Construcción sólida y precisa

- ▶ Available with coolant through spindle
- ▶ Possibilité d'arrosage par l'intérieur de la broche
- ▶ Lieferbar mit Kühlmittelzufuhr durch den Spindel
- ▶ Disponible con paso de refrigerante por el interior del husillo

- ▶ Add one axis to your machine
- ▶ Ajoute un axe supplémentaire à votre machine
- ▶ Geben Sie Ihrer Maschine eine zusätzliche Achse
- ▶ Añade un eje más a su máquina

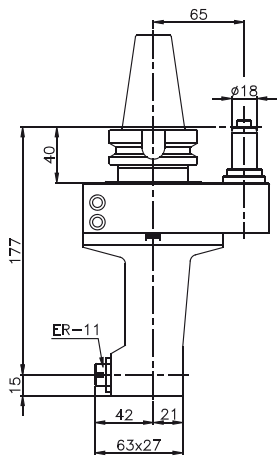

- CA-0C**
- ▶ Type for small room
 - ▶ Modèle pour les espaces réduits
 - ▶ Modell für schmale Plätze
 - ▶ Modelo para espacios reducidos

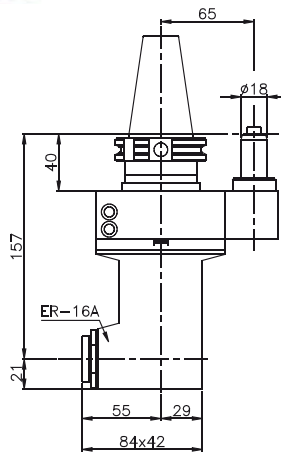

- CA-0E**
- ▶ Very versatile and light
 - ▶ Très souple et léger
 - ▶ Vielseitig und leicht
 - ▶ Muy versátil y ligero

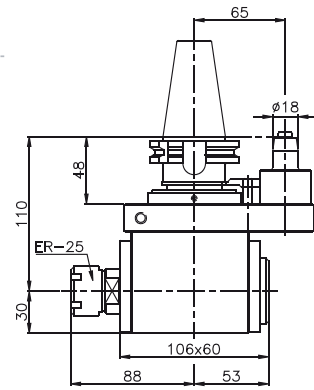

- CA-0**
- ▶ Small size, large capacity
 - ▶ Encombrement réduit, grande capacité
 - ▶ Geringe Größe, große Kapazität
 - ▶ Tamaño reducido, gran capacidad

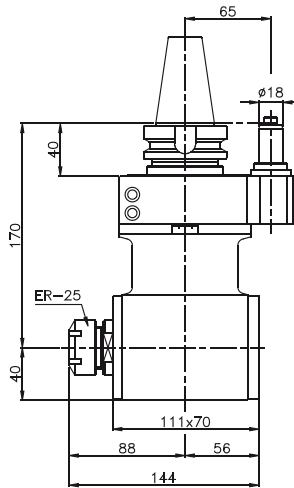

- CA-1**
- ▶ Wide range of spindles
 - ▶ Grand choix de broches
 - ▶ Breite Reihe von Spindeln
 - ▶ Gran selección de husillos

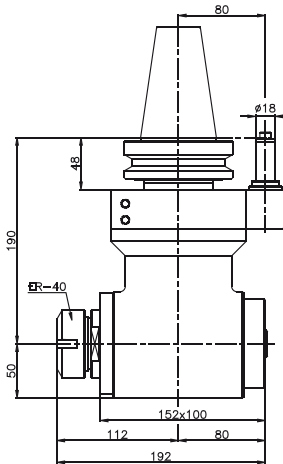

- CA-2**
- ▶ ISO taper = Flexibility of toolholders
 - ▶ Cône ISO = souplesse types d'outil
 - ▶ SK Kegel = Anpassungsfähigkeit der Werkzeughalter
 - ▶ Cono ISO = Flexibilidad tipos herramienta

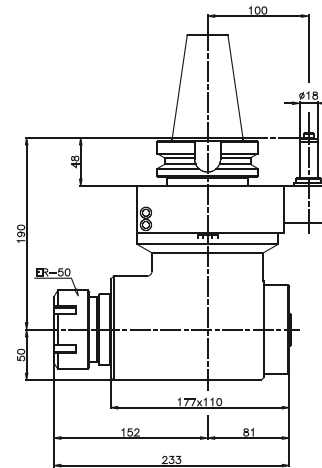

- CA-3**
- ▶ Optional outputs for all types (See page 11)
 - ▶ Sorties optionnelles pour tous les types (Voir page 11)
 - ▶ Wahlweise Ausgänge für alle Type (Siehe Seite 11)
 - ▶ Salidas opcionales para todos tipos (Ver pág.11)

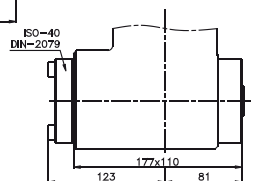
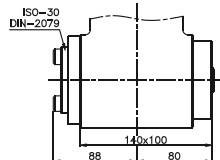
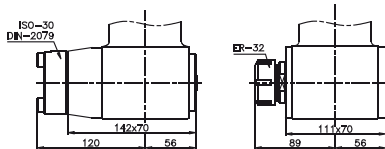

FEATURES / CARACTÉRISTIQUES / MERKMALE / CARACTERÍSTICAS

	CA-0C	CA-0E	CA-0	CA-1	CA-2	CA-3
R.P.M. max	4.000	4.000	5.000	3.000	2.500	2.000
KW	1	2	3.5	5	14	20
Ø MAX	7	10	16	16	26	34
KG	4	7	4	7	14	24
Ratio	1:1	1:1	1:1	1:1	1:1	1:1
Nm.max	4	6	11/14	31	140	175/220
ISO/DIN/MAS BT	30/40	40/50	30/40	40/50	50	50
HSK	50/63	63/100	50/63	63/100	80/100	80/100

AVAILABLE WITH ANY TYPE OF TAPER / LIVRABLE AVEC TOUT TYPE DE CÔNE / VERFÜGBAR MIT JEDER KEGELTYPE / SUMINISTRABLE EN CUALQUIER TIPO DE CONO





- ▶ Double indexing, maximum versatility
- ▶ Double indexation, souplesse maximale
- ▶ Doppelte Indexierung, höchste Anpassungsfähigkeit
- ▶ Doble indexación, máxima versatilidad

- ▶ Adaptable to all models of machines
- ▶ Adaptable sur toutes les machines
- ▶ Anpassbar an jede Art von Maschinen oder Bearbeitungszentren
- ▶ Adaptables a todo tipo de máquina

- ▶ 100% Checked and tested. Certification available
- ▶ 100% Rodés et vérifiés. Attestation disponible
- ▶ Unsere produkte sind zu 100% überprüft und getestet. Messprotokolle erhältlich
- ▶ Inspeccionados y rodados al 100%. Certificado disponible

- ▶ Fixed indexations every 15°
- ▶ Indexations fixes tous les 15°
- ▶ Feste Indexierung alle 15°
- ▶ Indexaciones fijas cada 15°

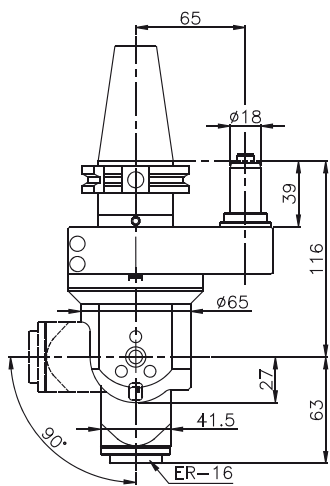

- CAR-0**
- ▶ Also available with ER-20 collet
 - ▶ Disponible également avec pince ER-20
 - ▶ Auch mit Spannzange ER-20 lieferbar
 - ▶ También disponible con pinza ER-20

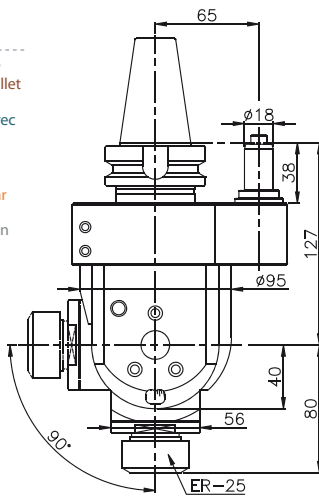

- CAR-1L**
- ▶ Minimum weight
 - ▶ Poids minime
 - ▶ Geringes Gewicht
 - ▶ Peso mínimo

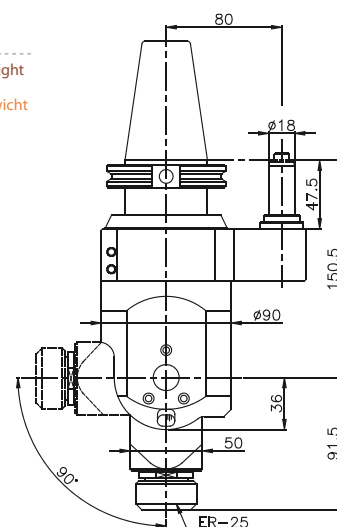

- CAR-1**
- ▶ Version for 8000 RPM available
 - ▶ Version pour 8000 TPM disponible
 - ▶ Ausführung für 8000 UPM lieferbar
 - ▶ Versión para 8000 RPM disponible

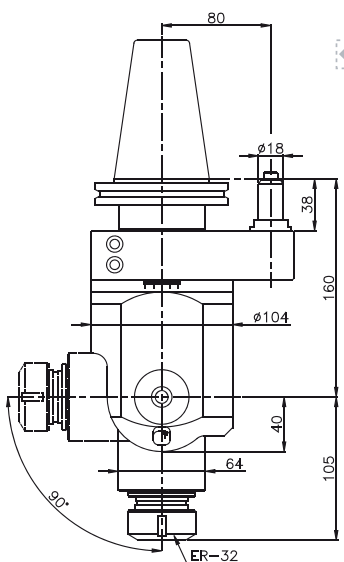

- CAR-2**
- ▶ Version for 6000 RPM available
 - ▶ Version pour 6000 TPM disponible
 - ▶ Ausführung für 6000 UPM lieferbar
 - ▶ Versión para 6000 RPM disponible

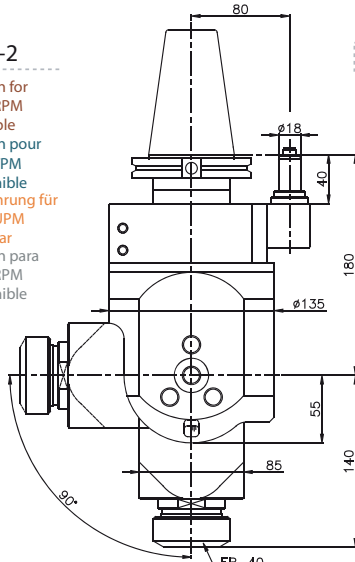

- CAR-3**
- ▶ Versatile, large capacity
 - ▶ Souple, grande capacité
 - ▶ Vielseitig, große Kapazität
 - ▶ Versátil, gran capacidad

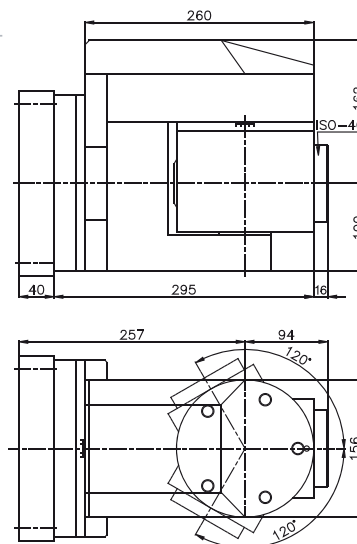

- CAR-4**
- ▶ Compact and robust
 - ▶ Compact et robuste
 - ▶ Kompact und robust
 - ▶ Compacto y robusto

FEATURES / CARACTÉRISTIQUES / MERKMALE / CARACTERÍSTICAS

	CAR-0	CAR-1L	CAR-1	CAR-2	CAR-3	CAR-4
R.P.M. max	8.000	10.000	4.000	4.000	3.500	3.000
KW	3.5	4	3.5	6	10	12
Ø MAX	10	16	16	20	26	34
KG	4	4.5	7	13	25	80
Ratio	1:1	1:1	1:1	1:1	1:1	1:1
Nm.max	10	20	12	22	40	100
ISO/DIN/MAS BT	30/40	40/50	40/50	50	50	*
HSK	50/63	63/100	63/100	80/100	80/100	*

(*) FLANGE MOUNTED GIVING INCREASED RIGIDITY / RIGIDITÉ SUPÉRIEURE LORDS DU MONTAGE PAR FLASQUE SUR LA MACHINE / ERHÖHTE STARRHEIT DURCH FLANSCHANBAU DIREKT AN DIE MASCHINE / EL MONTAJE CON PLATINA AUMENTA LA RIGIDEZ

(*) According to the machine / Suivant la machine / Nach der Maschine / Según máquina

Adjustable angle heads 0° - 90° (titanium) Cabecales angulares regulables 0° - 90° (titanio) Verstellbare Winkelköpfe 0° - 90° (Titan) Têtes à renvoi réglables 0° - 90° (titanium)

- ▶ High rotational speed
- ▶ Haute vitesse de rotation
- ▶ Hohe Spindeldrehzal
- ▶ Alta velocidad de rotación
- ▶ For high speed machining centres
- ▶ Pour centres d'usinage à grande vitesse
- ▶ Für Hochgeschwindigkeit-BAZ
- ▶ Para centros de mecanizado de alta velocidad
- ▶ Innovative high technology
- ▶ Technologie innovatrice
- ▶ Innovative Hochtechnologie
- ▶ Tecnología innovadora

- ▶ Smooth and quiet running thanks to the high precision gearing system
- ▶ Fonctionnement souple et silencieux, grâce la denture de précision des engrenages
- ▶ Ruhiger und geräuscharmer Lauf dank der hochpräzisen Verzahnung der Zahnräder
- ▶ Funcionamiento suave y silencioso gracias al dentado de precisión de los engranajes

Adjustable angle heads with increasing ratio Têtes à renvoi réglables avec rapport multiplicateur Verstellbare Winkelköpfe mit Übersetzungsverhältnis Cabecales angulares regulables con relación multiplicadora

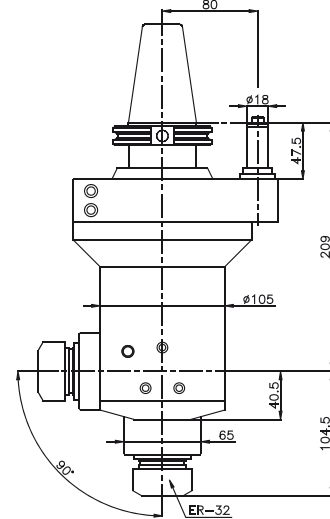

CAR-2X3

- ▶ High RPM for modern tools
- ▶ Haut TPM pour outils modernes
- ▶ Hohe UPM für moderne Werkzeuge
- ▶ Altas RPM para herramientas modernas

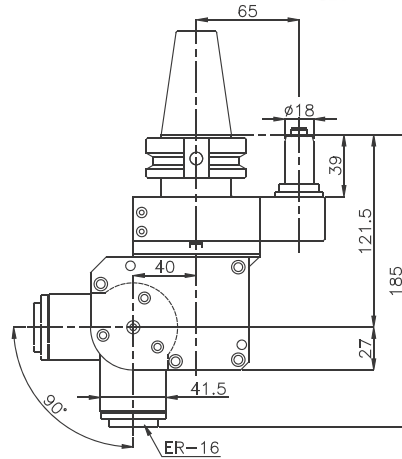

CAR-0X3

- ▶ Longer life for machines and tools
- ▶ Accroît la durée de vie machines et outils
- ▶ Höhere Lebensdauer für Maschinen und Werkzeuge
- ▶ Mayor vida en máquinas y herramientas

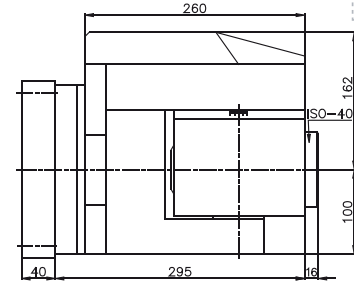

CAR-4X3

- ▶ Large cutting capacity
- ▶ Grande capacité de coupe
- ▶ Grosse Schnittkapazität
- ▶ Gran capacidad de corte

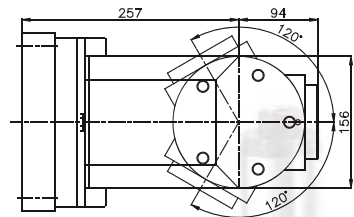

T I T A N I U M

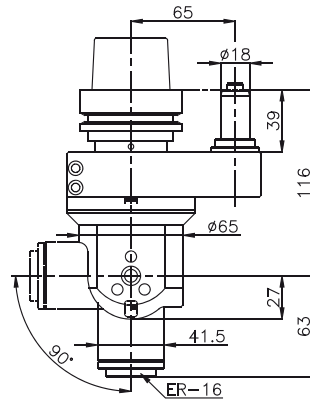

CAR-0T

- ▶ Great lightness, high speed
- ▶ Grande légèreté, haute vitesse
- ▶ Grosse Leichtigkeit, Hochgeschwindigkeit
- ▶ Gran ligereza, alta velocidad

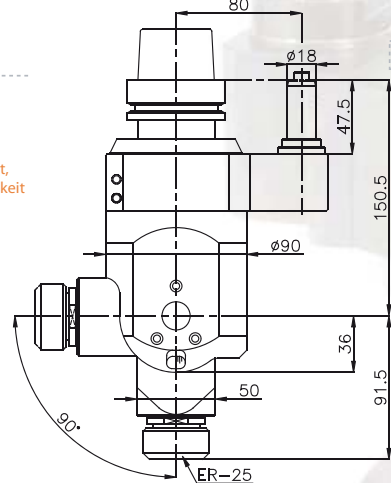

CAR-1T

- ▶ Versatile, light
- ▶ Souple, léger
- ▶ Vielseitig, leicht
- ▶ Versátil, ligero

- ▶ Titanium housing
- ▶ Corps de titane
- ▶ Gehäuse aus Titan
- ▶ Cuerpo de titanio

- ▶ Angle sight
- ▶ Vernier angulaire
- ▶ Winkelanzeige
- ▶ Visor angularidad

- ▶ Ceramic bearings
- ▶ Roulements céramiques
- ▶ Keramische lager
- ▶ Rodtos cerámicos

- ▶ Fixed indexations every 15°
- ▶ Indexations fixes chaque 15°
- ▶ Feste indexierung alle 15°
- ▶ Indexaciones fijas cada 15°

- ▶ Ceramic bearings
- ▶ Roulements céramiques
- ▶ Keramische lager
- ▶ Rodamientos cerámicos

12.000 RPM

FEATURES / CARACTÉRISTIQUES / MERKMALE / CARACTERÍSTICAS

	CAR-0X3	CAR-2X3	CAR-4X3	CAR-0T	CAR-1T
R.P.M. max	12.000	9.000	6.000	12.000	10.000
KW	2	4	10	3.5	3.5
Ø MAX	10	20	32	10	16
KG	6.2	23	85	3.3	5.5
➤	1:3	1:3	1:3	1:1	1:1
Nm.max	10	22	100	10	12
ISO/DIN/MAS BT	40/50	50	-	30/40	40/50
HSK	63/100	80/100	-	50/63	63/100

(*) According to the machine / Suivant la machine / Nach der Maschine / Según máquina.



FEATURES / CARACTÉRISTIQUES / MERKMALE / CARACTERÍSTICAS

	CAF-0	CAF-1	CAF-2	CAF-3
ISO	30/40	40/50	50	50
HSK	50/63	50/63	63/80/100	63/80/100
A (ISO)	38	47	38	40
A (HSK)	35/42	42	42/45	42/45
B	77	112.5	120	140
C	65	90	90	135
D	63	93	105	140
RPM	8.000	4.000	4.000	3.500
Nm.	10	12	22	40
Kw	3.5	3.5	6	10
	1:1	1:1	1:1	1:1
	2.6/3.1	5.5/7.5	11.3	15.8
	10	16	20	26
	M8	M14	M18	M22
	ER-16	ER-25	ER-32	ER-40

E > 0° - < 90°

(*) According to the machine / Suivant la machine / Nach der Maschine / Según máquina



ANGLE HEADS TÊTES À RENVOI D'ANGLE WINKELKÖPFE CABEZALES ANGULARES

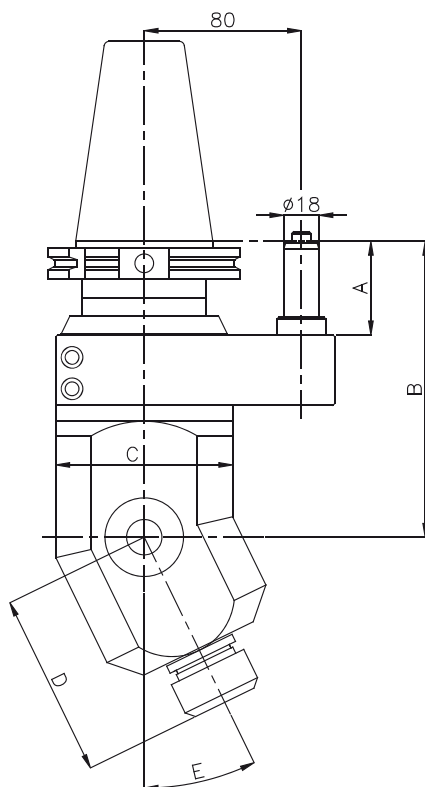

- ▶ It allows the acces to difficult machining areas
- ▶ Permet d'accéder à des endroits d'usinage difficile
- ▶ Bearbeitungsmöglichkeit an schwer zugänglichen Stellen
- ▶ Permite el acceso a lugares de difícil mecanizado
- ▶ Saving time by obviating operations
- ▶ Gain de temps pour supression du montage/démontage de la pièce
- ▶ Zeitensparung durch Wegfall von Umspannvorgängen
- ▶ Ahorro de tiempo al evitar distintos amarres de piezas
- ▶ Brilliant solutions to your machining problems
- ▶ Solutions astucieuses pour vos problèmes d'usinage
- ▶ Einfallsreiche Lösungen für Ihre Bearbeitungsprobleme
- ▶ Soluciones imaginativas a sus problemas de mecanizado
- ▶ Drilling, tapping, reaming, milling...
- ▶ Perçage, taraudage, alésage, fraisage...
- ▶ Bohren, Gewindeschneiden, Reiben, Fräsen...
- ▶ Taladrado, roscado, escariado, fresado...
- ▶ We meet your requirements
- ▶ Nous nous adaptons à vos besoins
- ▶ Wir entsprechen Ihren Anforderungen
- ▶ Nos adaptamos a su necesidad



- ▶ Tailor made to meet customer specifications
- ▶ Exécutions spéciales sur demande
- ▶ Sonderausführungen auf Anfrage
- ▶ Ejecuciones especiales bajo demanda
- ▶ Less interference in tool changer
- ▶ Moindre interférence dans le magasin d'outils
- ▶ Kleinere Interferenz im Werkzeuglager
- ▶ Menor interferencia en el almacén de herramientas

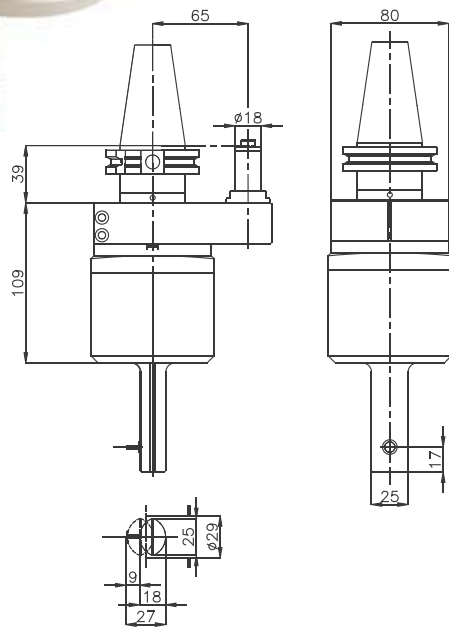

- CAP-0**
- ▶ Smaller size, upon request
 - ▶ Moindre taille, sur demande
 - ▶ Kleinere Größe, auf Anfrage
 - ▶ Menor tamaño, bajo demanda

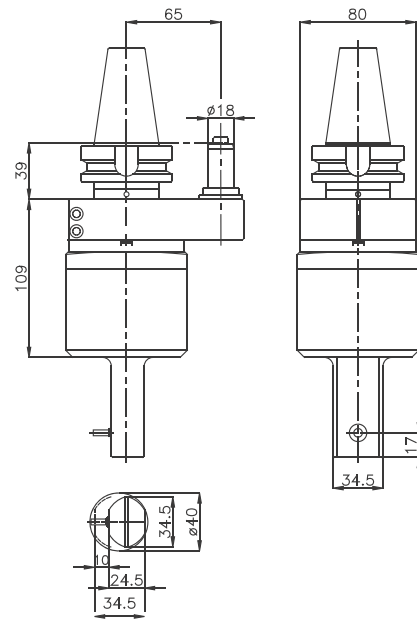

- CAP-1**
- ▶ For difficult machining areas
 - ▶ Pour les endroits d'accès difficile
 - ▶ Für schwer zugänglichen Stellen
 - ▶ Para lugares de difícil acceso

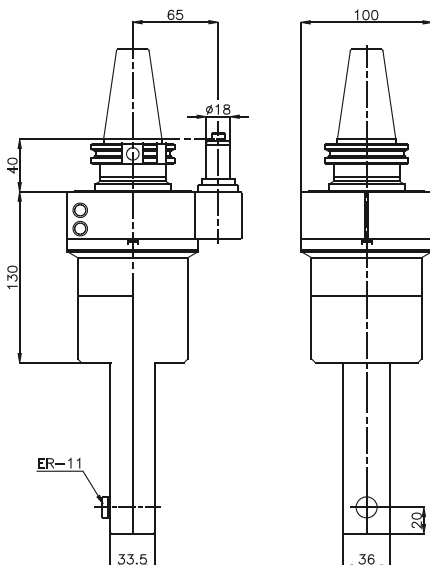

- CAP-2**
- ▶ Other dimensions upon request
 - ▶ D'autres longueurs et encombrements sur comande
 - ▶ Weitere Abmessungen auf Anfrage
 - ▶ Otras longitudes y dimensiones bajo demanda

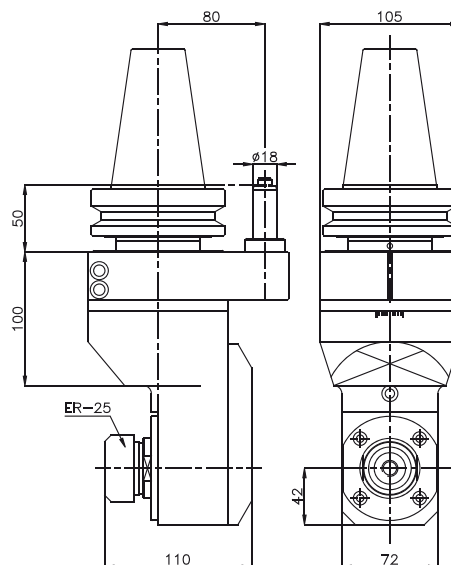

- CAP-3**
- ▶ Configuration for larger cutting capacity
 - ▶ Configuration pour une plus grande capacité de coupe
 - ▶ Gestaltung für grossere Schnittkapazität
 - ▶ Configuración para mayor capacidad de corte

FEATURES / CARACTÉRISTIQUES / MERKMALE / CARACTERÍSTICAS

	CAP-0	CAP-1	CAP-2	CAP-3
R.P.M. max	3.000	3.000	3.000	4.000
KW	1	1	1.4	5
Ø MAX	4	5	7	16
KG	4	5	7.5	9
↔	1:1	1:1	1:1	1:1
Nm.max	4	4	9	30
ISO/DIN/MAS BT	30/40	30/40	40/50	50
HSK	32/50/63	32/50/63	63/100	80/100

(*) According to the machine / Suivant la machine / Nach der Maschine / Según máquina

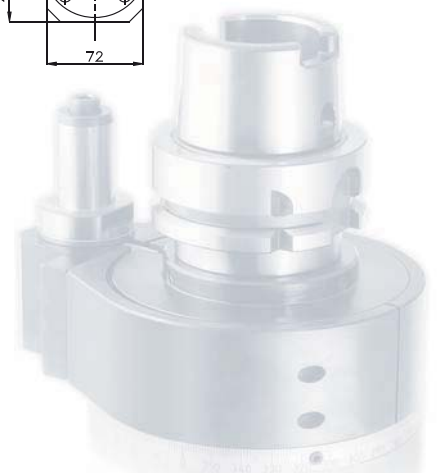



- ▶ High precision preloaded bearings
- ▶ Roulements de haute précision préchargés
- ▶ Hochpräzise, vorbelastete Wälzlager
- ▶ Rodamientos de precisión precargados

- ▶ Wide production range
- ▶ Programme de production complet
- ▶ Ein vollständiges Fertigungsprogramm
- ▶ Completo programa de producción

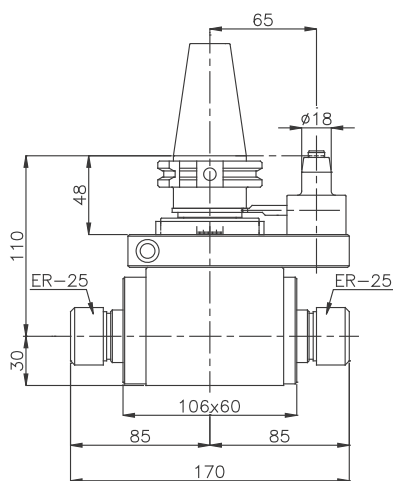
CAD-0

- ▶ Less tool changes
- ▶ Moins de changements d'outil
- ▶ Wenige Werkzeugwechsel
- ▶ Menos cambios de herramienta

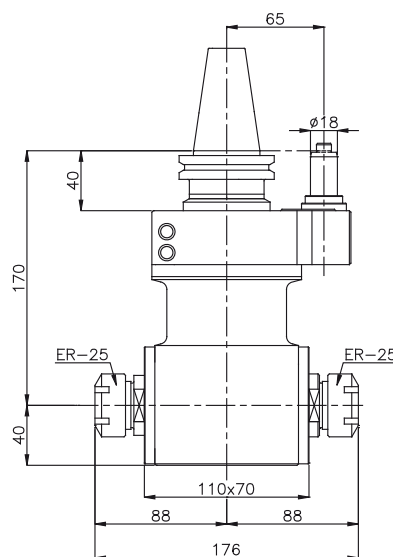
CAD-1

- ▶ Less room occupied in tool changer
- ▶ Moins d'espace occupé dans le magasin
- ▶ Wenig besetzter Platz im Lager
- ▶ Menos espacio ocupado en almacén

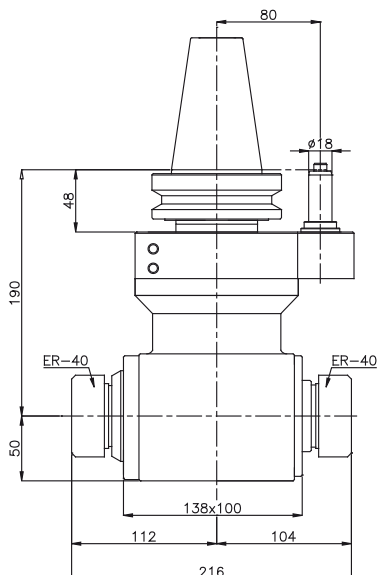
CAD-2

- ▶ Two heads in one
- ▶ Deux renvois en un
- ▶ Zwei Köpfe in einem
- ▶ Dos cabezales en uno

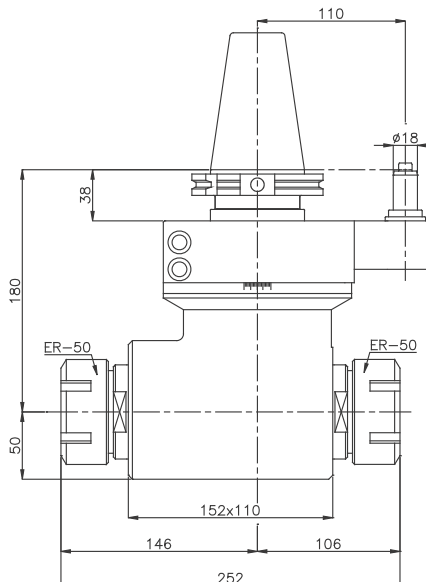
CAD-3

- ▶ Less costly machining process
- ▶ Moindre coût d'usinage
- ▶ Kostengünstiges Bearbeitungssystem
- ▶ Menos costes de mecanizado

FEATURES / CARACTÉRISTIQUES / MERKMALE / CARACTERÍSTICAS

	CAD-0	CAD-1	CAD-2	CAD-3
R.P.M. max	5.000	3.000	2.500	2.000
KW	3,5	5	14	20
Ø MAX	16	16	26	34
KG	5	8	15	25
↔	1:1	1:1	1:1	1:1
Nm.max	16	22	65	90
ISO/DIN/MAS BT	30/40	40/50	50	50
HSK	50/63	63/100	80/100	80/100

(*) According to the machine / Suivant la machine / Nach der Maschine / Según máquina

More than 7000 special manufactured types
Plus de 7000 modèles spéciaux déjà fabriqués
Über 7000 varianten zusätzlich zum Standard
Más de 7000 variantes realizadas sobre nuestro estándar



SPECIALS

EVERYTHING IS POSSIBLE
CHEZ NOUS, TOUT EST POSSIBLE
ALLES IST MÖGLICH
TODO ES POSIBLE



SPECIALS

- ▷ Some options can modify the dimensions on the catalogue
- ▷ Certaines options peuvent entraîner des modifications de l'encombrement indiqué dans le catalogue
- ▷ Einege Optionen verändern die Abmessungen im Katalog
- ▷ Ciertas opciones pueden hacer variar las dimensiones del catálogo



GRAFLEX TM
ABSTM Lic. Komet



Coromant Capto TM



HSK DIN 69063



Mill cutter holder
DIN 6358
Porte-fraises
DIN 6358
Fräseraufnahme
DIN 6358
Portafresas
DIN 6358



Quick change
tapping holder
Porte-taraud à
changement rapide
Gewindeschneid
Schnellwechselfutter
Portamachos
cambio rápido



Weldon
Whistle Nocht



Collet DIN 6499B
Pince DIN 6499B
Spannzange
DIN 6499B
Pinza DIN 6499B



All types of
indexations
Tous les types
d'indexation
Alle Type von
Indexierungen
Todo tipo de
indexaciones



Precision bearings with
ceramic balls
Roulements de précision
à billes céramiques
Hochpräzisionskeramische
Lager
Rodamientos cerámicos
de precisión



Stop-block suitable for all machines
types, available on request
Stop-block, livrable sur demande,
suivant les caractéristiques de la machine
Anschlagblock lieferbar auf Anfrage,
abmessungen je nach maschinentype
Stop-block disponible bajo demanda,
para todo tipo de máquina



Standard equipment
Équipement standard
Standardlieferung
Equipo estándar

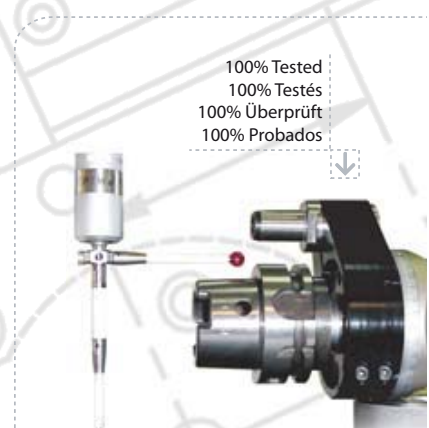

100% Tested
100% Testés
100% Überprüft
100% Probados

Compensation
tapping collets
Pincas de taraugage
compensées
Spannzangen mit
Gewindeschneidenausgleich
Pinzas para roscado
con compensación
Collets
Pincas
Spannzangen
Pinzas



▶ **High precision guaranteed**

Precision, rigidity, reliability together with technology in continuous improvement, are the qualities of our products both in standard and special construction.

▶ **Haute précision garantie**

Grâce à notre technologie de pointe et innovatrice, les principales qualités de nos produits sont la précision, la rigidité et la fiabilité, celles-ci étant appliquées sur notre production aussi bien standard que spéciale.

▶ **Hohe Präzision garantiert**

Präzision, Starrheit und Zuverlässigkeit in Verbindung mit ständiger technologischer Weiterentwicklung sind die Eigenschaften unserer Produkte, sowohl Standard als auch Sonderausführung.

▶ **Alta precisión garantizada**

Precisión, rigidez, fiabilidad unidos a tecnología en constante avance, son las cualidades de nuestros productos, tanto en ejecución estándar como especial.



MADDAULA S.A.
www.madula.com®

Rec del Molí, 11-17
08105 - Sant Fost de Campsentelles
BARCELONA - SPAIN
Tel. 34 93 593 36 00
Fax. 34 93 570 07 99
www.madula.com
e-mail: comercial@madula.com

